

# docce a barriera e lavapiedi per installazioni antimicotiche

*infrared walk-through showers and foots washer for antimycotic installations*

■ box n. 1



■ box n. 2 — mm. 90x90x50

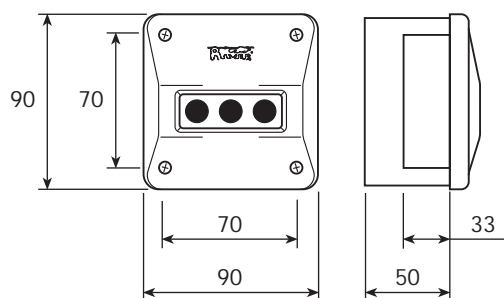

misure in cm.  
dimensions in cm.

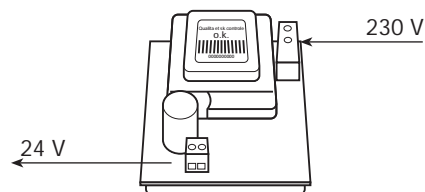
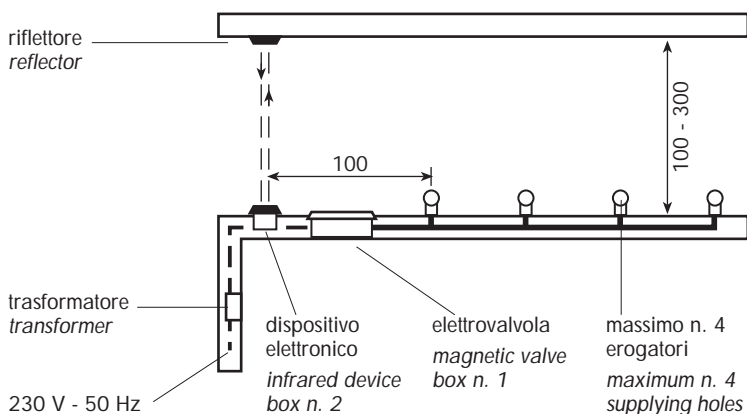

- pu essere installato anche quando le condizioni di luce non sono ottimali  
*can be installed also when there are adverse ambient light conditions*
- il tempo di erogazione regolabile da 1 a 10 sec.  
*adjustable flush time from 1 to 10 sec.*

## DOCCE E LAVAPIEDI A BARRIERA INFRARED WALK-THROUGH SHOWERS AND FOOTS WASHER

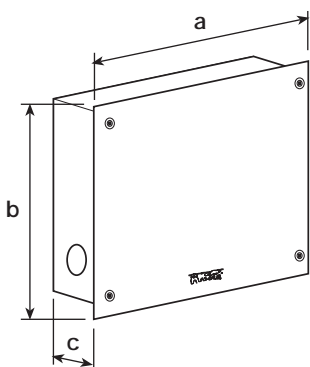

CODICE	mm a	mm b	mm c	TESTO DI CAPITOLATO
E2078	240	190	80	<p>dispositivo elettronico da incasso con riflettore per docce o lavapiedi — alimentazione a rete 230V - 50Hz con trasformatore — portata l/min. 70 a 3 bar — incorporato rubinetto Ø 1/2" con filtro inox per eventuale manutenzione</p> <p>2 scatole per il montaggio:</p> <ul style="list-style-type: none"> <li>■ scatola n. 1 da incasso prof. 80 mm. con premontati rubinetto di chiusura, filtro inox ed elettrovalvola con chiusura progressiva</li> <li>■ scatola n. 2 dispositivo elettronico con riflettore e trasformatore</li> </ul> <p><i>recessed infrared device with reflector for showers or foots washer 230V - flow rate 70 l/min. at 3 bar</i></p> <ul style="list-style-type: none"> <li>■ box n. 1 hydraulic part and magnetic valve</li> <li>■ box n. 2 infrared device with reflector and transformer</li> </ul>